

A-A (1 : 11)

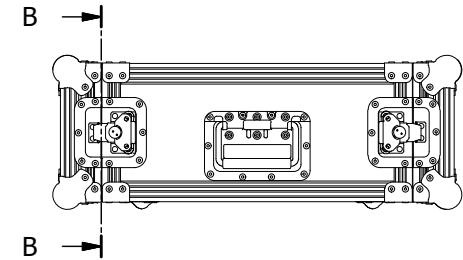

B-B (1 : 11)

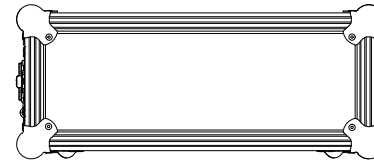
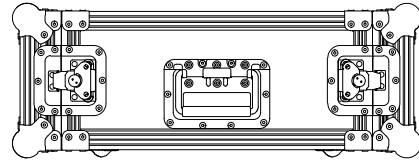
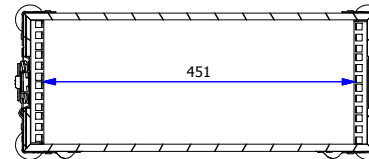
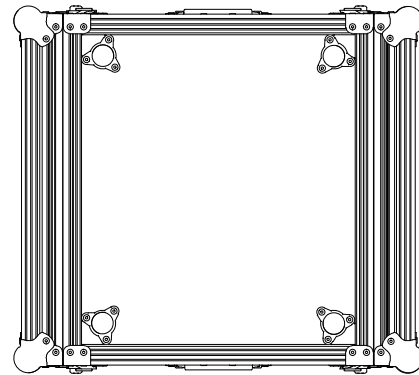
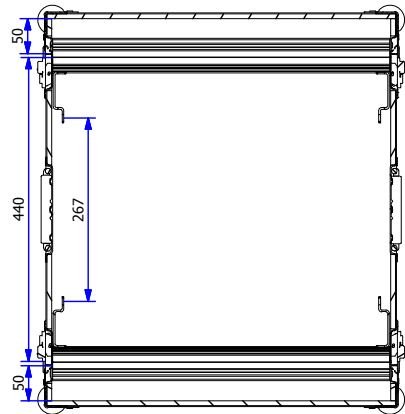

External Dimensions (excluding hardware): 510W x 573D x 201H

Parts List	
QTY	DESCRIPTION
8	Medium Ball Corner 4120
16	L-Bracket 4043
4	Steel Foot 4936
2	Recessed Flip Handle 34082
4	Med Padlocking Butterfly Catch L908/915/07
4	Double Full Hole Rackstrip R0883
1	Dragon Badge

Drawing no: F194USTD	Issue: 1	Sheet: 1	Wall Thickness: 7mm	Wall Colour/Material: 7mm laminated ply/Astraboard	Hardware Details: See parts list.
Title: 4u Standard 19" Rack Flightcase with 440mm Sleeve			Drawn by: J.B.	Company: AN Other	
			Date: 08/10/2008		

Specifications:
 1. Aluminium extrusions riveted through wall material every 100mm.
 2. Bifurcated rivets to be used wherever possible.
 3. All hardware zinc plated.
 4. No foam.
 5. Rack rails front + rear.
 6. Estimated weight - 10.8kgs

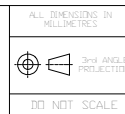

ALL DIMENSIONS IN MILLIMETRES
 THIS DRAWING IS COPYRIGHTED BY DRAGON CASES. IT MUST NOT BE COPIED OR DISCLOSED WITHOUT CONSENT OF THE OWNER



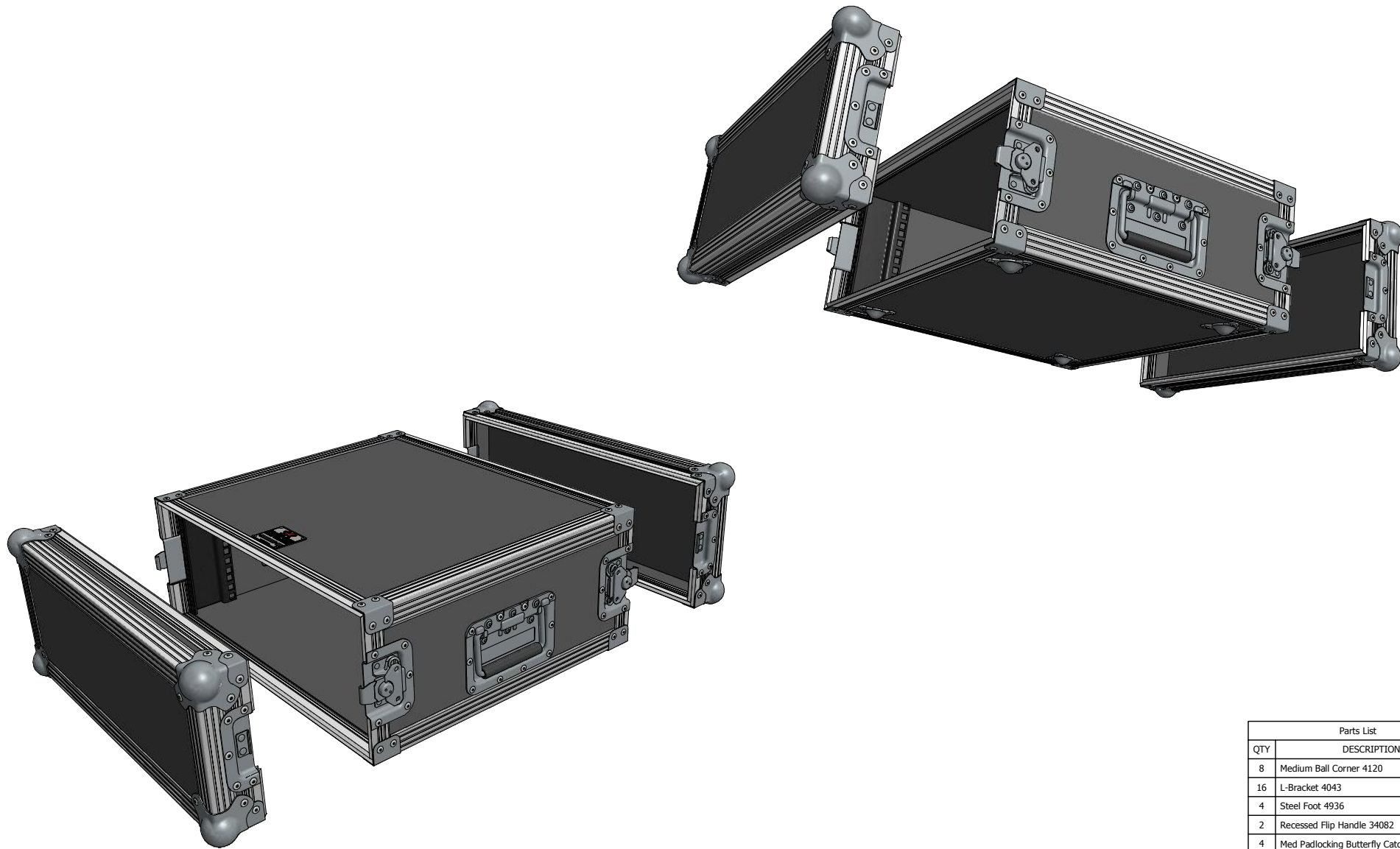

External Dimensions (excluding hardware): 510W x 573D x 201H

Parts List	
QTY	DESCRIPTION
8	Medium Ball Corner 4120
16	L-Bracket 4043
4	Steel Foot 4936
2	Recessed Flip Handle 34082
4	Med Padlocking Butterfly Catch L908/915/07
4	Double Full Hole Rackstrip R0883
1	Dragon Badge

Drawing no: F194USTD	Figure: 1	Sheet: 3	Wall Thickness: 7mm	Wall Colour/Material: 7mm laminated ply/Astraboard	Hardware Details: See parts list.	Specifications: 1. Aluminium extrusions riveted through wall material every 100mm. 2. Bifurcated rivets to be used wherever possible. 3. All hardware zinc plated. 4. No foam. 5. Rack rails front + rear. 6. Estimated weight - 10.8kgs	ALL DIMENSIONS IN MILLIMETRES  DO NOT SCALE	THIS DRAWING IS COPYRIGHTED BY DRAGON CASES. IT MUST NOT BE COPIED OR DISCLOSED WITHOUT CONSENT OF THE OWNER	 DRAGON CASES in partnership with Nomad PLC tel: 01633 791590 fax: 01633 791531
Title: 4u Standard 19" Rack Flightcase with 440mm Sleeve		Drawn by: J.B.		Company: AN Other					
		Date: 8/10/08							