

External Dimensions (excluding hardware): 741L x 491W x 396H

Void to house extending handle.

Parts List			
QTY	DESCRIPTION	TYPE	FOAM
6	Large Flat Corner 4004		
8	L-Bracket 4043		
3	Recessed Flip Handle 34082		
1	Recessed Extending Handle H2017		
2	Shallow Med P/locking Butterfly Catch L908-915-07		
2	HD Strut Hinge 2524		
1	52mm Piano Hinge 2606		
1	Dragon Badge		
4	38mm Rubber Foot 4911		
2	Recessed Corner Wheel W8675HD		
4	Flexi Rail Length		
4	Flexi Rail Width		
1	False Floor		
2	Foam Box Side	LD18	6 mm
2	Foam Box End	LD18	6 mm
1	Foam Box Bottom	LD18	6 mm
2	Foam Lid Side	LD18	6 mm
2	Foam Lid End	LD18	6 mm
1	Foam Lid Bottom	LD18	6 mm

Drawing no:	FRFT4	Issue/Sheet:	1 / 4
Title:		Wall Thickness:	7mm
Standard Rolling Flexi-Trunk 4		Wall Colour/Material:	Black Astraboard
		Drawn by:	JB
		Date:	12/12/11
		Company:	XXX
		Hardware Details:	See Parts List

Specifications:	<ol style="list-style-type: none"> 1. Aluminium extrusions riveted through wall material every 100mm. 2. Bifurcated rivets to be used wherever possible. 3. All hardware zinc plated. 4. Internal surfaces lined with 6mm LD18 foam. 5. Optional Movable 6mm ply partitions. 6. Estimated weight - 13.1kgs
-----------------	--



ALL DIMENSIONS IN MILLIMETRES	<p>THIS DRAWING IS COPYRIGHTED BY DRAGON CASES. IT MUST NOT BE COPIED OR DISCLOSED WITHOUT CONSENT OF THE OWNER</p>
	<p>in partnership with Nomad PLC</p> <p>tel: 01633 791590 fax: 01633 791531</p>

<p>DRAGON CASES</p>

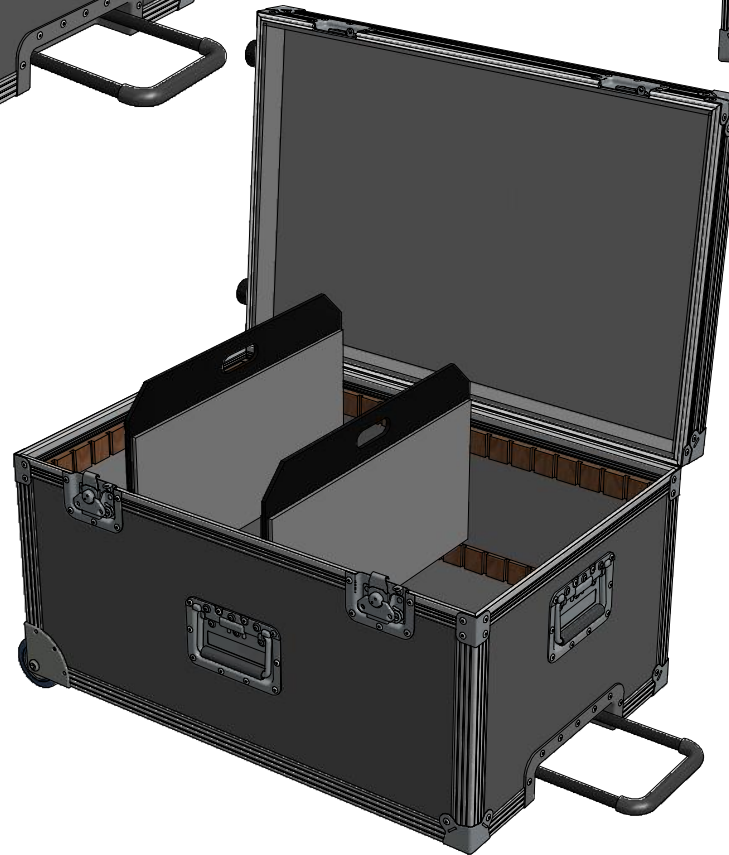
<p>DO NOT SCALE</p>



External Dimensions (excluding hardware): 741L x 491W x 396H

Drawing no: FRFT4	Issue: 1	Sheet: 2/4	Wall Thickness: 7mm	Wall Colour/Material: Black Astraboard	Hardware Details: 	Specifications: 1. Aluminium extrusions riveted through wall material every 100mm. 2. Bifurcated rivets to be used wherever possible. 3. All hardware zinc plated. 4. Internal surfaces lined with 6mm LD18 foam. 5. Optional Movable 6mm ply partitions. 6. Estimated weight - 13.1kgs	ALL DIMENSIONS IN MILLIMETRES  DO NOT SCALE	THIS DRAWING IS COPYRIGHTED BY DRAGON CASES. IT MUST NOT BE COPIED OR DISCLOSED WITHOUT CONSENT OF THE OWNER	 DRAGON CASES in partnership with Nomad PLC tel: 01633 791590 fax: 01633 791531
Title: Standard Rolling Flexi-Trunk 4		Drawn by: JB		Company: XXX					
		Date: 12/12/11							