

External Dimensions (excluding hardware): 666L x 441W x 396H

QTY	DESCRIPTION	TYPE	FOAM
6	Large Flat Corner 4004		
8	L-Bracket 4043		
3	Recessed Flip Handle 34082		
1	Recessed Extending Handle		
2	Shallow Med P/locking Butterfly Catch L908-915-07		
2	HD Strut Hinge 2524		
1	52mm Piano Hinge 2606		
4	38mm Rubber Foot 4911		
2	Recessed Corner Wheel W8675HD		
1	Dragon Badge		
1	False Floor		
4	Flexi Rail Length		
4	Flexi Rail Width		
1	Foam Box Bottom	LD18	6 mm
2	Foam Box Side	LD18	6 mm
2	Foam Box End	LD18	6 mm
2	Foam Lid Side	LD18	6 mm
2	Foam Lid End	LD18	6 mm
1	Foam Lid Bottom	LD18	6 mm

Drawing no:	FRFT3	Issue:	1	Sheet:	1/4
Title: Standard Rolling Flexi-Trunk 3					

Wall Thickness:	7mm	Wall Colour/Material:	Black Astraboard
Drawn by:	JB	Company:	XXX
Date:	12/12/11		

Hardware Details:	See Parts List.
Specifications:	<ol style="list-style-type: none"> 1. Aluminium extrusions riveted through wall material every 100mm. 2. Bifurcated rivets to be used wherever possible. 3. All hardware zinc plated. 4. Internal surfaces lined with 6mm LD18 foam. 5. Optional Movable 6mm ply partitions. 6. Estimated weight - 12.2kgs.

ALL DIMENSIONS IN MILLIMETRES	3-4 ANGLE PROJECTOR
DO NOT SCALE	



THIS DRAWING IS COPYRIGHTED BY DRAGON CASES. IT MUST NOT BE COPIED OR DISCLOSED WITHOUT CONSENT OF THE OWNER.

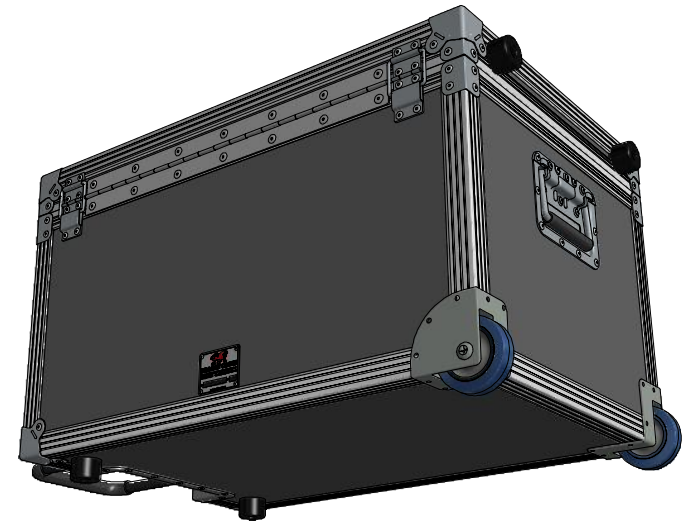

DRAGON CASES
in partnership with Nomad PLC
tel: 01633 791590
fax: 01633 791531



External Dimensions (excluding hardware): 666L x 441W x 396H

Drawing no: FRFT3	Issue: 1	Sheet: 2 / 4	Wall Thickness: 7mm	Wall Colour/Material: Black Astraboard	Hardware Details: 	Specifications: 1. Aluminium extrusions riveted through wall material every 100mm. 2. Bifurcated rivets to be used wherever possible. 3. All hardware zinc plated. 4. Internal surfaces lined with 6mm LD18 foam. 5. Optional Movable 6mm ply partitions. 6. Estimated weight - 12.2kgs.	ALL DIMENSIONS IN MILLIMETRES  DO NOT SCALE	THIS DRAWING IS COPYRIGHTED BY DRAGON CASES. IT MUST NOT BE COPIED OR DISCLOSED WITHOUT CONSENT OF THE OWNER	 DRAGON CASES in partnership with Nomad PLC tel: 01633 791590 fax: 01633 791531
Title: Standard Rolling Flexi-Trunk 3		Drawn by: JB	Company: XXX						
		Date: 12/12/11							