

Parts List			
QTY	DESCRIPTION	TYPE	FOAM
6	Large Flat Corner 4004		
8	L-Bracket 4043		
3	Recessed Flip Handle 34082		
1	Recessed Extending Handle H2017		
2	HD Strut Hinge 2524		
1	52mm Plano Hinge 2606		
2	Shallow Med P/locking Butterfly Catch L908-915-07		
4	38mm Rubber Foot 4911		
2	Recessed Corner Wheel W8675HD		
1	Dragon Badge		
1	False Floor		
4	Flexi Rail Length		
4	Flexi Rail Width		
1	Foam Box Bottom	LD18	6 mm
2	Foam Box Side	LD18	6 mm
2	Foam Box End	LD18	6 mm
1	Foam Lid Bottom	LD18	6 mm
2	Foam Lid Side	LD18	6 mm
2	Foam Lid End	LD18	6 mm

External Dimensions (excluding hardware): 666L x 441W x 321H

Drawing no:	FRFT2	Issue/Sheet	1 / 4
Title:	Standard Rolling Flexi-Trunk 2	Wall Thickness:	7mm
		Wall Colour/Material:	Black Astroboard
		Hardware Details:	See Parts List.
		Drawn by:	J.B.
		Date:	12/12/11
		Company:	xxx

Wall Thickness:	7mm
Wall Colour/Material:	Black Astroboard
Hardware Details:	See Parts List.
Drawn by:	J.B.
Date:	12/12/11
Company:	xxx

Specifications:	<ol style="list-style-type: none"> 1. Aluminium extrusions riveted through wall material every 100mm. 2. Bifurcated rivets to be used wherever possible. 3. All hardware zinc plated. 4. Internal surfaces lined with 6mm LD18 foam. 5. Optional Movable 6mm ply partitions. 6. Estimated weight - 10.6kgs.
-----------------	---



ALL DIMENSIONS IN MILLIMETRES	
DO NOT SCALE	

THIS DRAWING IS COPYRIGHTED BY DRAGON CASES. IT MUST NOT BE COPIED OR DISCLOSED WITHOUT CONSENT OF THE OWNER

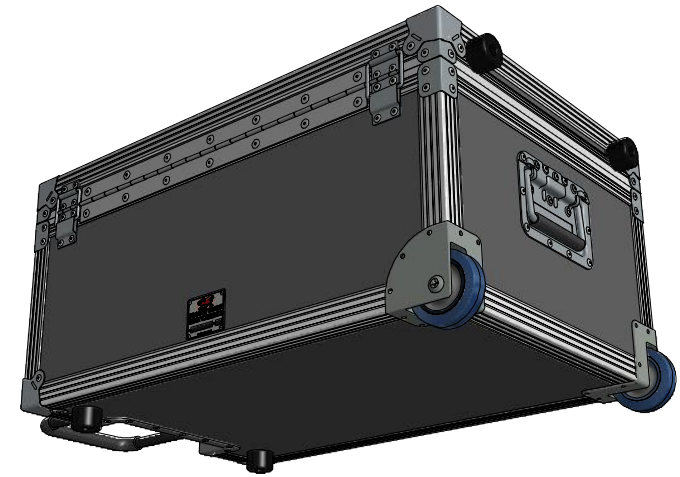



External Dimensions (excluding hardware): 666L x 441W x 321H

Drawing no: FRFT2	Issue/Sheet: 1 / 2 / 4	Wall Thickness: 7mm	Wall Colour/Material: Black Astroboard	Hardware Details: See Parts List.	Specifications: 1. Aluminium extrusions riveted through wall material every 100mm. 2. Bifurcated rivets to be used wherever possible. 3. All hardware zinc plated. 4. Internal surfaces lined with 6mm LD18 foam. 5. Optional Movable 6mm ply partitions. 6. Estimated weight - 10.6kgs.	ALL DIMENSIONS IN MILLIMETRES  DO NOT SCALE	THIS DRAWING IS COPYRIGHTED BY DRAGON CASES. IT MUST NOT BE COPIED OR DISCLOSED WITHOUT CONSENT OF THE OWNER	 DRAGON CASES in partnership with Nomad PLC tel: 01633 791590 fax: 01633 791531
Title: Standard Rolling Flexi-Trunk 2		Drawn by: J.B.	Company: XXX					