

External Dimensions (excluding hardware): 591L x 391W x 321H

Parts List			
QTY	DESCRIPTION	TYPE	FOAM
6	Large Flat Corner 4004		
8	L-Bracket 4043		
3	Recessed Flip Handle 34082		
1	Recessed Extending Handle		
2	Recessed Corner Wheel W8675HD		
2	HD Strut Hinge 2524		
1	52mm Piano Hinge 2606		
2	Shallow Med P/locking Butterfly Catch L908-915-07		
2	25x25 Rubber Foot F1691		
2	38x25 Rubber Foot 4911		
1	Dragon Badge		
1	False Floor		
4	Flexi Rail Length		
4	Flexi Rail Width		
1	Foam Box Bottom	LD18	6 mm
1	Foam Lid Bottom	LD18	6 mm
2	Foam Box Side	LD18	6 mm
2	Foam Box End	LD18	6 mm
4	Foam Partition	LD18	6 mm
2	Foam Lid Side	LD18	6 mm
2	Foam Lid End	LD18	6 mm

Drawing no:	FRF1	Issue/Sheet:	1 / 4	Wall Thickness:	7mm	Wall Colour/Material:	Black Astraboard	Hardware Details:	See Parts List
Title:	Standard Rolling Flexi-Trunk 1	Drawn by:	J.B.	Date:	11/12/11	Company:	XXX		

1. Aluminium extrusions riveted through wall material every 100mm.
2. Bifurcated rivets to be used wherever possible.
3. Internal surfaces lined with 6mm LD18 foam.
4. Optional Movable 6mm ply partitions.
5. Estimated weight - 9.2kgs.



ALL DIMENSIONS IN MILLIMETRES
 3rd ANGLE PROJECTION
 DO NOT SCALE

THIS DRAWING IS COPYRIGHTED BY DRAGON CASES. IT MUST NOT BE COPIED OR DISCLOSED WITHOUT CONSENT OF THE OWNER

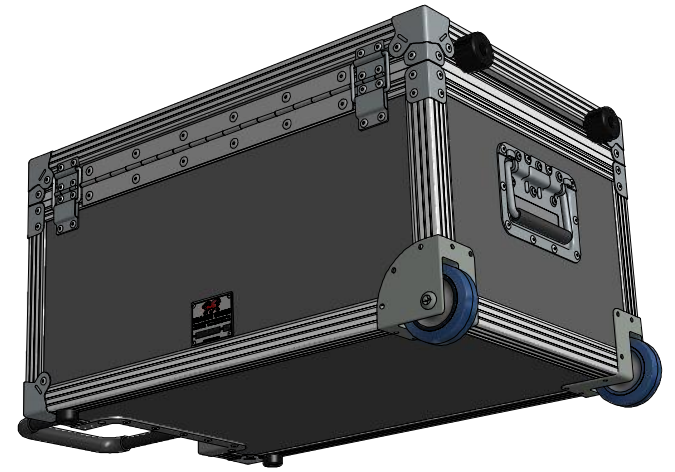
DRAGON CASES
 in partnership with Nomad PLC
 tel: 01633 791590
 fax: 01633 791531



External Dimensions (excluding hardware): 591L x 391W x 321H

Drawing no: FRFT1	Issue: 1	Sheet: 2/4	Wall Thickness: 7mm	Wall Colour/Material: Black Astroboard	Hardware Details: 1. Aluminium extrusions riveted through wall material every 100mm. 2. Bifurcated rivets to be used wherever possible. 3. Internal surfaces lined with 6mm LD18 foam. 4. Optional Movable 6mm ply partitions. 5. Estimated weight - 9.2kgs.	ALL DIMENSIONS IN MILLIMETRES  DO NOT SCALE	THIS DRAWING IS COPYRIGHTED BY DRAGON CASES. IT MUST NOT BE COPIED OR DISCLOSED WITHOUT CONSENT OF THE OWNER	 DRAGON CASES in partnership with Nomad PLC tel: 01633 791590 fax: 01633 791531
Title: Standard Rolling Flexi-Trunk 1		Drawn by: J.B.		Company: XXX				