

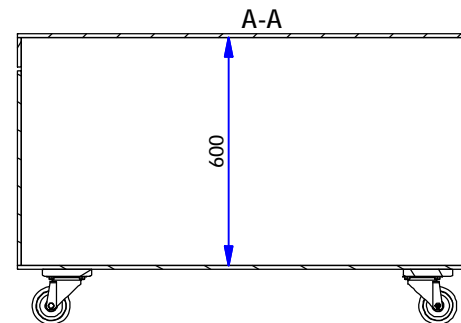

Panel & Interior Details

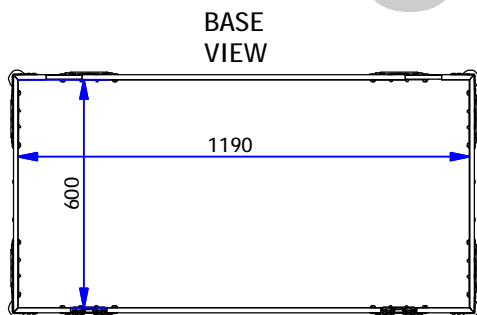
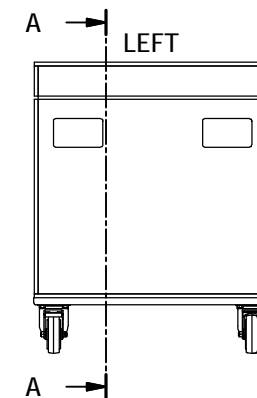
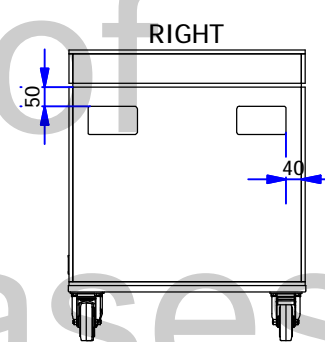
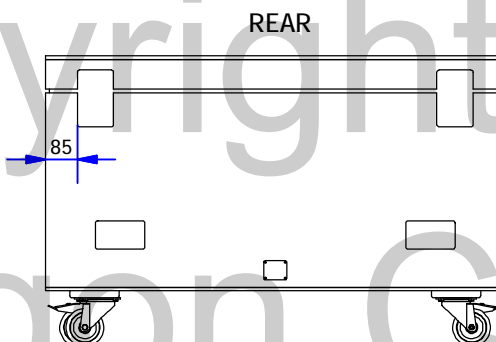
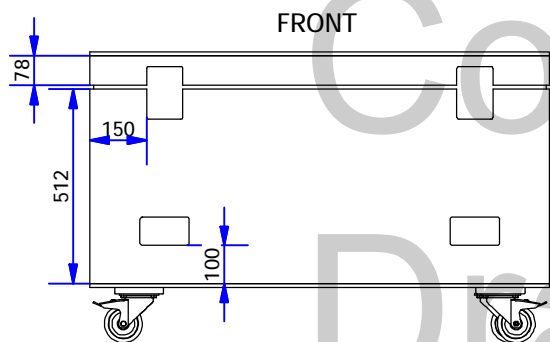

External Dimensions (excluding hardware); 1216L x 626W x 623H

Drawing no: <b>FRT7</b>	Issue No: <b>1</b>	Sheet <b>1</b>	Wall Thickness: <b>10mm</b>	Wall Colour/Material: <b>Laminate/Phenol faced Ply</b>	Hardware Details: Piano hinged lid with stays. Recessed butterfly catches. Recessed flip handles with rubber grips. Steel ball corners + L/T brackets. 100mm swivel castors (2 braked).	Specifications: 1. Aluminium extrusions riveted through wall material every 100mm. 2. Bifurcated rivets to be used wherever possible. 3. All hardware zinc plated. 4. No Foam Lining.	ALL DIMENSIONS IN MILLIMETRES 3rd ANGLE PROJECTION DO NOT SCALE	THIS DRAWING IS COPYRIGHTED BY DRAGON CASES. IT MUST NOT BE COPIED OR DISCLOSED WITHOUT CONSENT OF THE OWNER	 <b>DRAGON CASES</b> in partnership with Nomad PLC tel: 01633 791590 fax: 01633 791531
Title: <b>Standard Roadtrunk 7</b>			Drawn by: I.C.	Company: <b>AN Other</b>					