

Internal Subframe suspended with 8 rubber shockmounts (weight bearing 50Kg,90Kg or 200Kg)

**Panel & Interior Details**

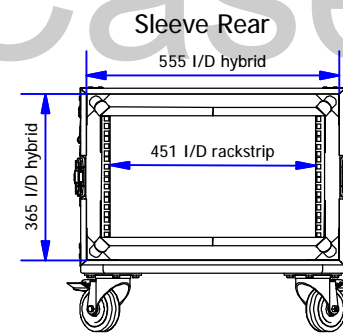
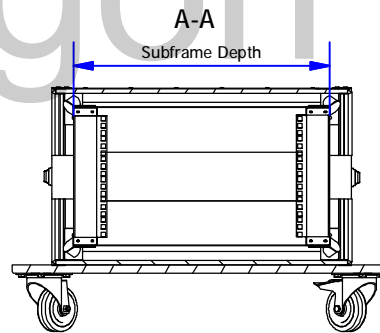
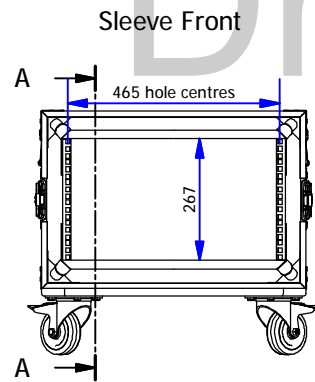
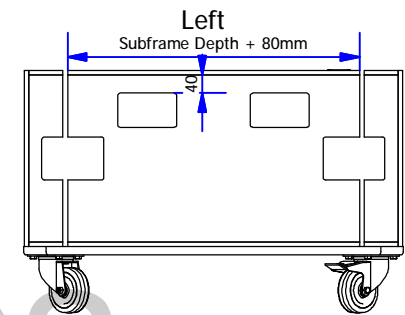
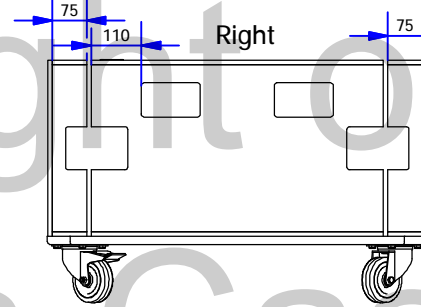
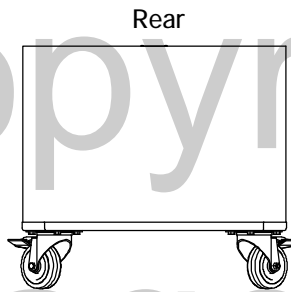
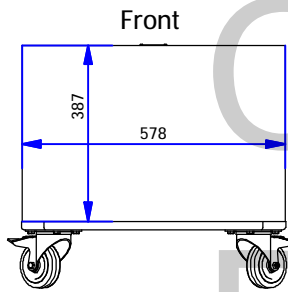

Available Subframes	
Subframe Depth	Panel Depth
362mm	442mm
407mm	482mm
462mm	542mm
507mm	587mm
562mm	642mm
607mm	687mm
662mm	742mm
707mm	787mm
762mm	842mm
807mm	887mm

**NOTES**  
xxxkg Shockmounts

External Dimensions (excluding hardware) - 581W x 835D x 390H

Drawing no: <b>F196USM</b>	Issue/Sheet <b>1 / 1</b>	Wall Thickness: <b>10mm</b>	Wall Colour/Material: <b>Laminate/phenol faced ply</b>	Hardware Details: Recessed butterfly catches. Recessed flip handles with rubber grips. Steel ball corners + L/T brackets. Steel punched rackstrips front + rear. 100mm swivel castors (2 braked)	Specifications: 1. Aluminium extrusions riveted through wall material every 100mm. 2. Bifurcated rivets to be used wherever possible. 3. All hardware zinc plated. 4. No foam.	ALL DIMENSIONS IN MILLIMETRES 3/4 ANGLE PROJECTION DO NOT SCALE	THIS DRAWING IS COPYRIGHTED BY DRAGON CASES. IT MUST NOT BE COPIED OR DISCLOSED WITHOUT CONSENT OF THE OWNER	 <b>DRAGON CASES</b> In partnership with Nomad PLC tel: 01633 791590 fax: 01633 791531	
Title: <b>6u Shockmounted Rack Flightcase with xxxmm Subframe</b>		Drawn by: <b>IC</b>	Company: <b>AN Other</b>						
		Date: <b>05/11/2008</b>							